



TECHNICAL NOTES on Brick Construction

1850 Centennial Park Drive, Suite 301, Reston VA 20191 | www.gobrick.com | 703-620-0010

Technical Notes 36A - Brick Masonry Details, Caps and Copings, Corbels and Racking Rev [Sept./Oct. 1981] (Reissued February 2001)

Abstract: Recommendations are provided for the development of successful details using brick masonry. Detailing of caps, copings, corbels and racking is specifically addressed. Performance, esthetic value and economics are the principal considerations in the develops meant of successful details.

Key Words: brick, caps, connections, construction, copings, corbels, design, detailing, economics, esthetic values, function, performance, racking, structural stability.

INTRODUCTION

This *Technical Notes* is the second in a series that discusses brick masonry details. This *Technical Notes* will address the detailing of caps, copings, corbels and racking. *Technical Notes* 36 Revised addresses the detailing of sills and soffits.

The recommended approach to detailing is covered in *Technical Notes* 36 Revised. While that *Technical Notes* is primarily for sills and soffits, it does provide the general approach applicable to all detailing. The following items should be considered in the development of a successful detail: 1. Functional considerations; 2. Esthetic value; 3. Construction considerations; 4. Economic considerations.

DEFINITIONS

Caps and Copings

The definitions for cap and coping are entirely dependent upon which dictionary or glossary is used as a reference. In addition, there are other terms which are used interchangeably with them, such as water table, canting strip, and offset. For the purpose of this *Technical Notes*, the word "coping" applies to the covering at the top of a wall, and the term "cap" refers to a covering within the height of the wall, normally where there is a change in wall thickness. The other terms cited will not be used.

Corbels and Racking

A corbel is defined as a shelf or ledge formed by projecting successive courses of masonry *out* from the face of the wall. Racking is defined as masonry in which successive courses are stepped *back* from the face of the wall.

CAPS AND COPINGS

General

The primary function of caps and copings is to channel water away from the building. The cap or coping may be a single unit or multiple units. They may be of several different materials. The tops may slope in one direction or both directions. Additionally, where caps are discontinuous, a minimum slope from the ends of 1/8 in. (3 mm) in 12 in. (300 mm) should be provided, as shown in Figures 4 and 6 in *Technical Notes* 36 Revised.

The esthetic value the designer wishes to achieve may come from the configuration of the element, its

color, or its texture. Caps and copings normally do not serve any structural function, and do not present any major problems in their construction.

Materials

Caps and copings can be constructed of several materials: brick, pre-cast or cast-in-place concrete, stone, terra cotta, or metal. It should be pointed out that because of their location in the structure, caps and copings are exposed to climatic extremes. This severe exposure must be of prime concern to the designer. Because caps and copings are subjected to extreme exposure, brick masonry may not be the best choice of materials. This is because caps and copings of brick require more joints than do those made of other materials. This provides more avenues for possible water penetration into the wall. If brick is the material selected, great care must be taken to provide for the movement to which the element will be subjected and also to make sure all joints are properly filled with mortar. Concrete, stone and metal caps and copings can be installed in relatively long pieces, thus requiring less joints than do those made from brick.

Concrete, stone and terra cotta all have thermal expansion properties similar to those of brick masonry and normally present no extreme problems with differential movement when applied as caps and copings, if properly detailed. Metal has very different thermal expansion properties than brick masonry. Depending upon the metal used, its thermal expansion coefficient may be 3 to 4 times that of brick masonry. The designer should be aware of this and provide for this differential movement in the development of the details. Consideration must also be given to the drying shrinkage of the element if cast-in-place concrete is the material selected.

If brick is the material chosen for the coping, it may be desirable in some applications to use a special shape to get a positive slope in two directions. In most applications, the slope should be only in one direction, with drainage onto the roof and not down the wall face. In such case, the coping can be built using regular shapes.

Design

The prime consideration in the design of caps and copings is the performance of the element in service. The designer must take into consideration the movement of the element, differential movement between the element and the wall, joint configuration and material, connection of the element to the wall, and type and location of flashings.

The esthetic value of the detail should be evaluated. As with details of other elements, selection of material, color, texture and configuration will effect the esthetic value of the detail. The designer has a wide range from which to choose, but he must keep in mind that the performance should not be compromised to achieve esthetic value.

The economic considerations are seldom a major consideration in the development of details for caps and copings. The material selected may have a minor effect on the economics of the detail. It affects the economics not only by its own costs, but also by the economics of installation. The economic considerations should not have a deleterious effect on the performance of the details in service.

Details

General. The function of caps and copings is to prevent the entry of water into the wall where the wall becomes partially or totally discontinuous vertically. Caps should have the top surface sloping downward, away from the face of the wall above. Copings may slope in one or both directions. In all cases, the slope should be a minimum of 15 degrees from horizontal.

The caps should overhang the wall face on the exposed side. Copings should overhang the wall on both sides. The overhang should be of sufficient dimension so that the inner lip of the drip is at least 1 in. (25 mm) from the face of the wall. Since the function of caps and copings is to prevent moisture penetration, the fewer the number of joints, the more assurance that the detail will perform its function.

Flashing and Weepholes. Flashings for caps and copings generally serve a different function from

flashings used elsewhere in the structure. Flashing used with caps and copings has as its prime function the prevention of the entry of moisture into the wall. The collection and diversion of the water from the wall becomes a secondary, although important function.

In order to properly anchor caps and copings to the wall, it may become necessary to penetrate the flashing with the anchor, see Figs. 1, 3, and 4. To prevent moisture from entering the wall, at these points, it is absolutely necessary that the penetrations be adequately sealed, or the flashing will fail to function as intended.

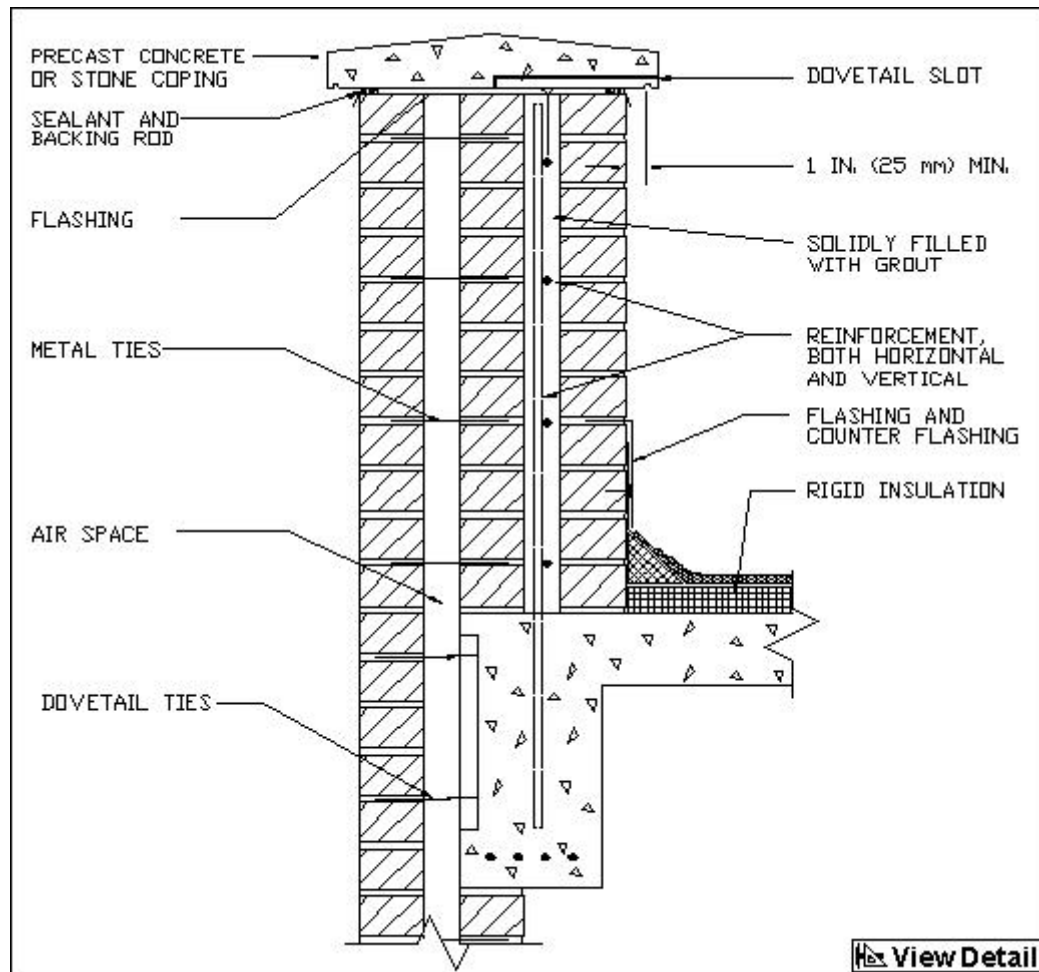

Precast Concrete or Stone Coping on Cavity Wall Parapet

FIG. 1

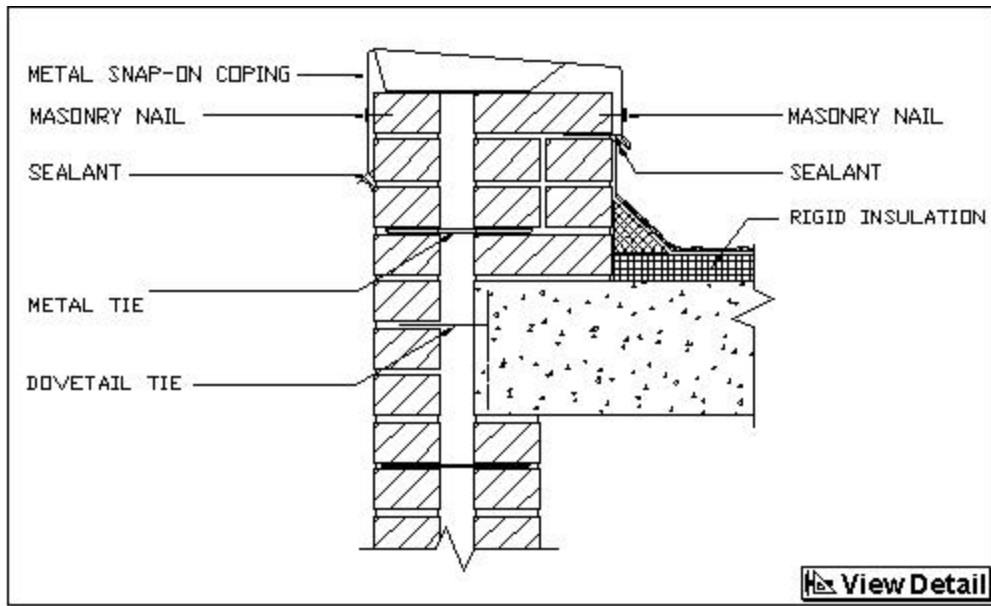

Coping for Cavity Wall Parapet

FIG. 2

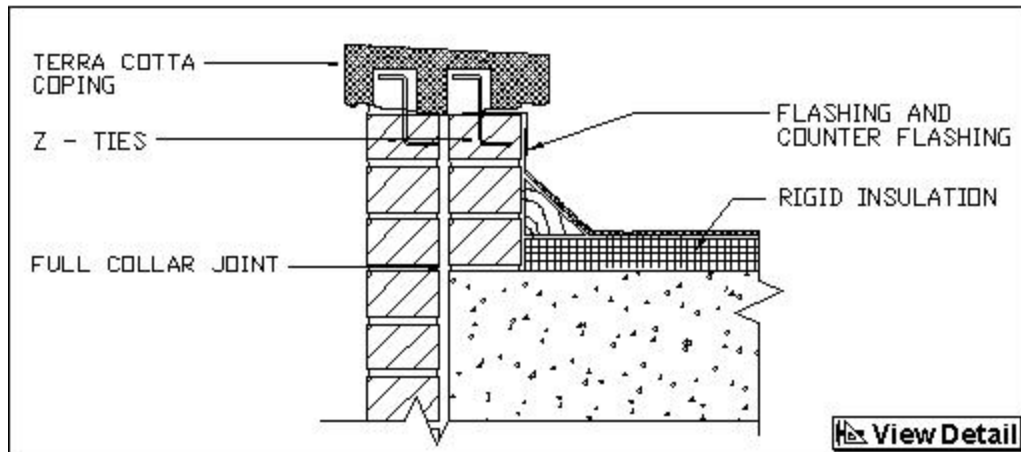

Coping for Solid Masonry Parapet

FIG. 3

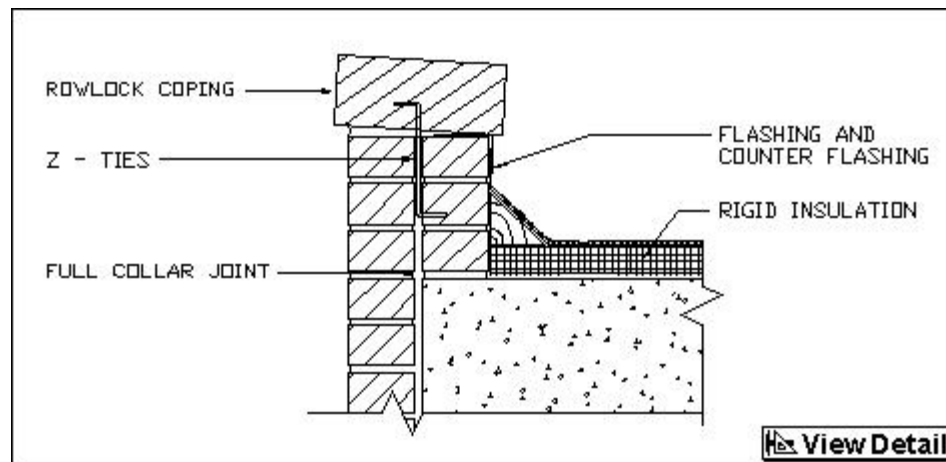

Rowlock Coping on Solid Masonry Parapet

FIG. 4

Flashings should be extended beyond the face of the wall and bent downward 1/4 in. (6 mm) to form a drip, as shown in Figs. 2, 5, and 6. Metal copings may also serve as flashings. It should be recognized that exterior flashings not contained within the wall serve the same functions as do interior flashing. Information on flashing materials is provided in *Technical Notes 7A Revised*.

While the flashing for caps and copings may have a different prime function from normal usage, it is still necessary to provide weepholes immediately above the flashings to convey the water collected on the flashing out of the wall, unless exterior flashing is used. Weepholes should be spaced at a maximum of 24 in. (600 mm) o.c., unless wicks or hidden flashing are used. Then the spacing should be reduced to 16 in. (400 mm) o.c. maximum.

Drips. Regardless of the material selected for caps or copings, drips should be provided. When brick caps and copings are used, the drip is the lowest point on the element, as shown in Figs. 4 and 7. When metal caps and copings are used, the drips can be formed by bending the material outward from the face of the wall, see Figs. 2, 5 and 6. With heavy gauge metals, stone concrete or terra cotta caps and copings, the drip is either cut or formed in the bottom of the projection beyond the face of the wall, as shown in Figs. 1, 3, and 7. This drip can be in several configurations, and still perform. The important thing is that a drip be provided and that the inner lip be at least 1 in. (25 mm) from the face of the wall as shown in Figs. 1, 3, and 7.

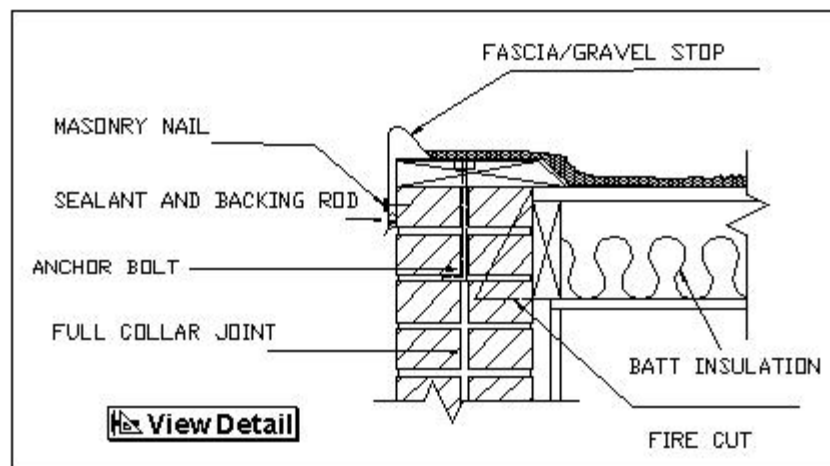

Masonry Bearing Wall Coping

FIG. 5

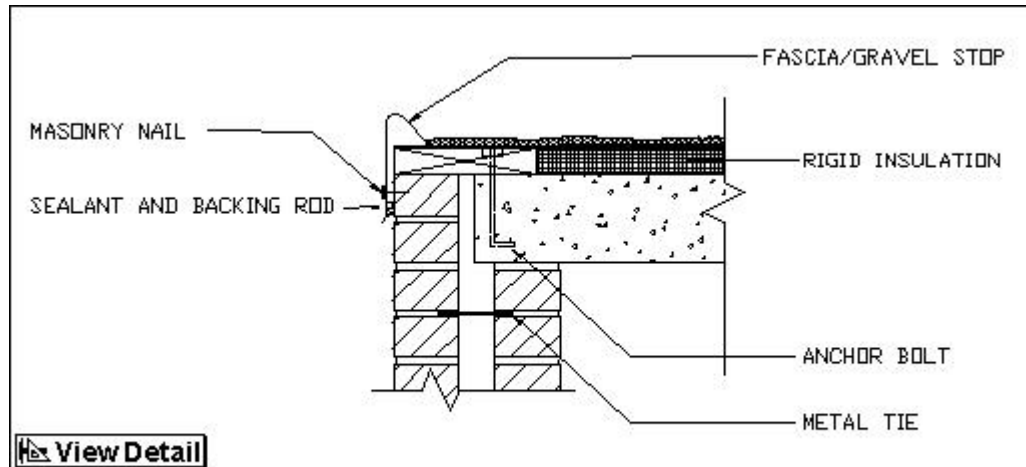

Masonry Cavity Wall Coping

FIG. 6

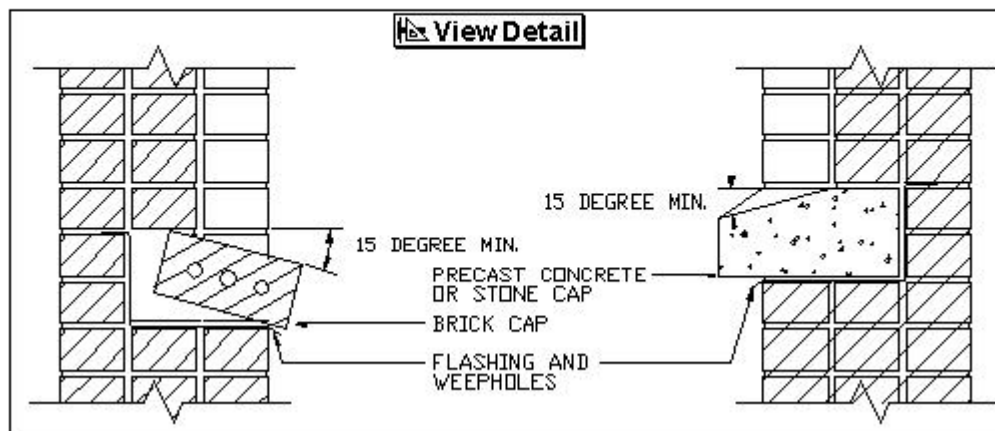

Brick and Precast Concrete or Stone Caps

FIG. 7

Connections. Elements other than caps and copings require careful consideration of their connection to the structure for the structural stability of the element. In the case of caps and copings, the structural stability becomes secondary to the climatic considerations, such as moisture and temperature. Connections which are usually provided for structural purposes are generally rigid. Because of the diversity of materials used for caps and copings in conjunction with brick masonry walls, the connection in some cases should be of a flexible nature. Brick masonry, concrete, stone and terra cotta, respond to climatic conditions in much the same manner, and rigid connections can be used with little consideration of differential movement. Because of the dissimilarity of metal and brick masonry in their reaction to climatic conditions, the connections require some flexibility.

Light gauge metal copings as shown in Figs. 5 and 6 should be nailed to the wall, and horizontal slots should be provided at nailing locations to prevent buckling of the coping due to thermal expansion. Metal caps and copings require an extension down the face of the wall, 4 in. (100 mm) min., and a sealant between the metal and the wall to prevent wind uplift and water penetration. Care should be taken to seal each penetration of the metal cap or coping where it is exposed to the exterior environment.

Expansion Joints. It is necessary to provide expansion joints in long walls to provide for movement of the wall due to thermal and moisture expansion. This is particularly true in parapet walls and other masonry walls which are exposed to the exterior climatic conditions on both sides. Expansion joints are discussed in *Technical Notes 18 Series*.

When expansion joints are required in the wall, the expansion joints should also be provided through any caps or copings in the same locations. It may be necessary to provide additional joints in metal copings. Metal copings should be so detailed and constructed that they function independently of the movement of the wall below. Expansion joints should be of a compressible material, but should also be extensible. One method of providing expansion joints is to leave the mortar from the head joints in a vertical line and insert a synthetic backer rod to the desired depth and fill the remainder of the joint with a high-quality sealant.

Construction. Caps and copings require no special construction skills. If brick masonry is used as the cap or coping material, great care should be taken to ensure that all head and bed joints are completely filled. If cast-in-place concrete is used, some provision must be made to allow for the initial drying shrinkage of the concrete.

If precast concrete or stone are used for caps or copings, non-compressible shims should be placed on the top of the wall at the exterior face of the wall. The shims are used because the weight of this type of cap or coping would compress the plastic mortar and a smaller joint would result. Then the mortar for the bed joint is spread and the cap or coping installed. The shims which should have a thickness equal to the bed joints should be left in place until the mortar has set. Once the mortar has set, the shims should be removed and the joint tuckpointed.

CORBELS AND RACKING

General

Corbeling of brick masonry may be done to achieve the desired esthetics, or to provide structural support. There are empirical requirements provided by most codes and standards for unreinforced corbels, as shown in Fig. 8. If these requirements are to be exceeded, then the element will require a rational design as a reinforced element.

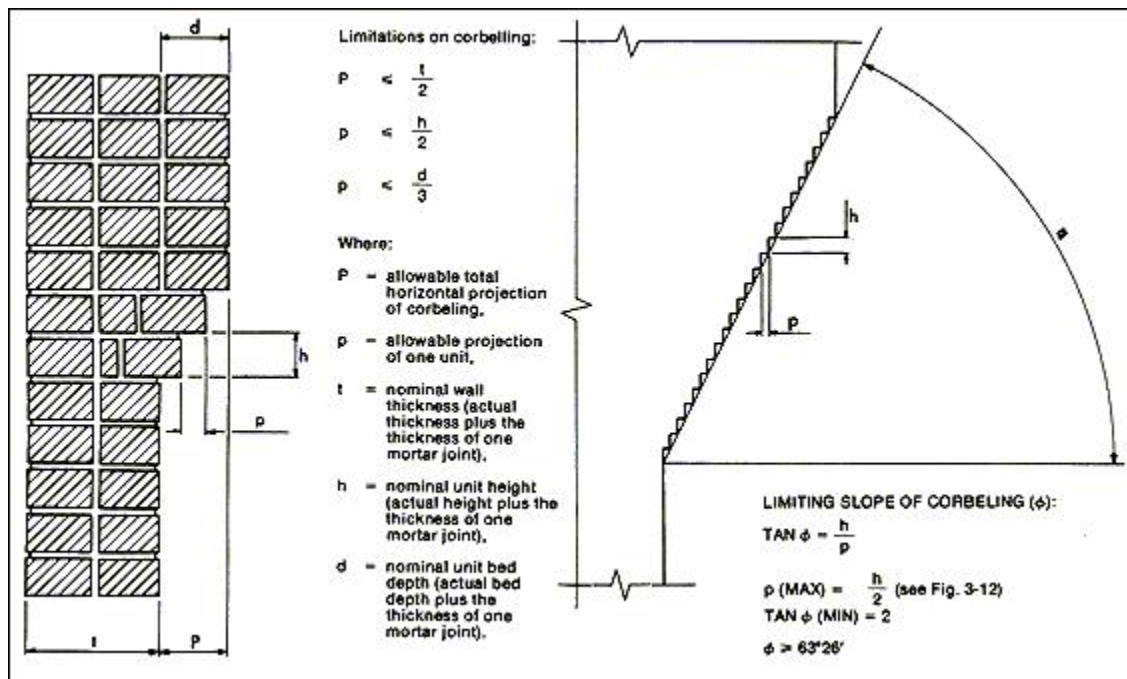

Limitations on Corbeling

FIG. 8

Corbels. The empirical approach requires that the total horizontal projection not exceed one-half the thickness of a solid wall, or one-half the thickness of the veneer of a veneered wall. It is also required that the projection of a single course not exceed one-half of the unit height or one-third of the unit bed depth, whichever is less. From these limitations, the minimum slope of the corbeling can be established (angle measured from the horizontal to the face of the corbeled surface is 63 deg 26 min. see Fig. 8). The required slope could be increased by the requirements that the unit projection not exceed one-third of the bed depth if they are more restrictive. It should be pointed out that the eccentricity induced into the wall by the corbeling must be considered in the wall design. If these limitations are exceeded, the wall should be reinforced to resist the stresses developed by the corbeling.

Fig. 9 illustrates graphically the pattern of stresses within two corbels of different configurations under identical loading conditions. The corbel on the left is 45 degrees from horizontal, which is not in accordance with building code requirements. The corbeled wall on the right has an angle of corbel 60 degrees from horizontal and is very close to the building code requirement of 63 degree 26 min discussed above. The 60 degree corbel shows a stress pattern with axial and shear stresses with the only concentration of stresses directly below the applied load, P. The shear stresses are well distributed within the wall section. The 45 degree corbel, on the other hand, has bending stresses in addition to the axial and shear stresses, and the pattern of the stresses has been drastically altered. In addition to the concentration of compressive stresses immediately beneath the load, P, there is another concentration of compressive stress at the toe of the corbel. The bending stresses require that a corbel of this configuration be rationally designed and reinforced. Those corbels having an angle from horizontal of 60 degree or greater do not require reinforcement unless they exceed the other requirements given above.

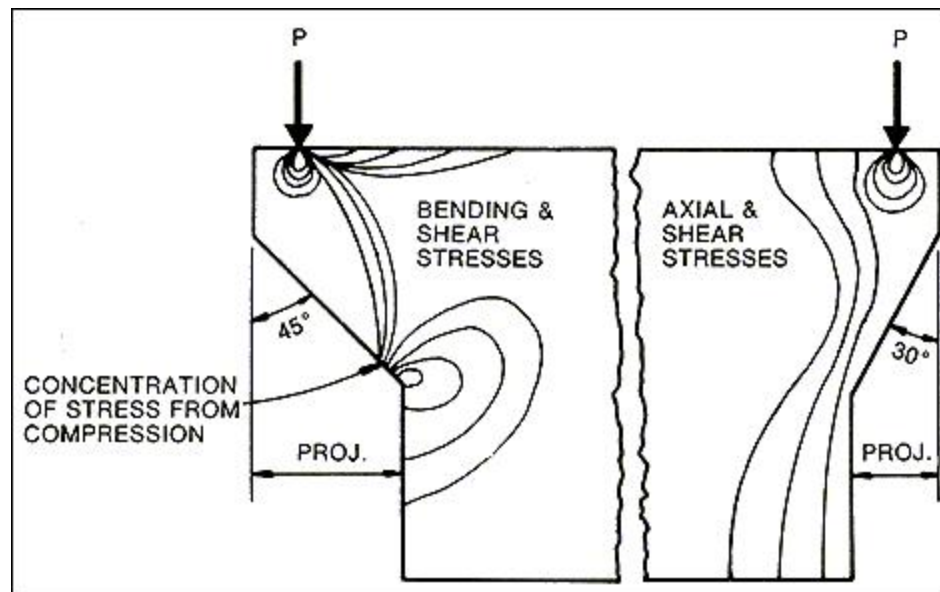

Corbeling Stress Distribution

FIG. 9

Racking. When racking back to achieve the desired dimensions, care must be exercised to insure that, since there is no limitation on the distance each unit may be racked, the cores of the units are not exposed. Preferred construction consists of a setting bed over the racked face with the uncured brick or paving brick set to provide a weather-resistant surface. Mortar washes may also be used. They may not, however, be as durable. When using a mortar wash, it should not bridge over the rack, but should fill each step individually.

SUMMARY

The designer, when developing details for caps, copings, corbels and racking should keep in mind the function of the element being detailed, the esthetic value he wishes to achieve, the structural stability of the element, and the economics of construction. It is essential to provide details which allow the elements to perform their primary functions as well as possible. In order to do this, the designer must select the proper materials, locate them in the proper place and provide sufficient information so that the element can be properly constructed. Several decisions and assumptions must be made by the designer because each project and each element on the project must be satisfactorily addressed.

The information and suggestions contained in this *Technical Notes* are based on the available data and the experience of the technical staff of the Brick Industry Association. The information and recommendations contained herein if followed with the use of good technical judgment, will avoid many of the problems discussed here. Final decisions on the use of details and materials as discussed are not within the purview of the Brick Industry Association, and must rest with the project designer, owner, or both.